



The Door to Quality.

5283 / 5983

ALL-STEEL SANDWICH CARRIAGE HOUSE DOOR



www.chiohd.com

C.H.I. OVERHEAD DOORS



Pictured. 18' x 7' 5283 almond door with optional stockton inserts; 9' x 7' 5283 almond door with optional stockton inserts and stamped hardware both doors



8' x 7' 5983 white with optional madison window inserts and wrought iron external hardware

MODEL 5283	Short Stamp, Insulated
MODEL 5983	Long Stamp, Insulated

- 2" door sections are formed from 27-gauge exterior galvanized draw quality steel
- Section joints are roll-formed into a tongue-and-groove design which produces a superior weather seal
- 1-13/16" CFC⁷ free polystyrene insulation, glued on both sides
- Extra heavy paint system² available in white, almond or sandstone
- Accents wood tones available in cedar, mahogany, dark oak and light oak
- Optional Appearance Package³ upgrade available
- Long-lasting rollers assure consistent, efficient operation
- Bottom weather seal utilizes an aluminum retainer and extruded virgin vinyl
- Concealed steel plates run continuously from top to bottom of each section for fastening hardware
- Extension or torsion springs are individually computer-calibrated to lift your door
- Hinges are stamped from galvanized steel in a "wide body" pattern for greater stability and longer life
- One set of spade decorative hardware is standard for all doors. Optional Barcelona⁶ or Wrought Iron designs replicate an old-world look
- Exterior decorative hardware includes 4 hinges, 2 handles and pop rivets for mounting to face
- R-value¹: 9.65

This model also available in



For additional information, please see numbered end-notes on backside.

Replicating the natural beauty of wood - the 5283 and 5983 present the visual distinction of wood carriage house doors while offering years of maintenance free service. The added benefits of a double-sided steel doors with CFC⁷ free polystyrene insulation will offer protection against the natural elements while adding structural integrity to the door. Available in three designer colors and numerous window designs, the 5283 or 5983 will provide direct architectural appeal and add value to your home for years to come.

VALUE-ADDED. FASHIONABLE.

FEATURES















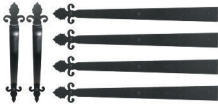

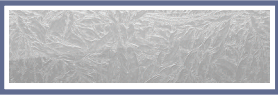



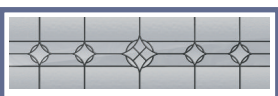

WINDOW & GLASS OPTIONS

Add a touch of elegance and complement the outside of your home with the addition of decorative and designer glass options from C.H.I. These options are an investment designed to improve the natural beauty of your exterior while adding to the value of your home.



The Door to Quality.

STANDARD WINDOW DESIGN TRIMS	DESIGNER LITES [®]	EXTERNAL HARDWARE
 Cascade	 Plain	 Spade
 Stockton	 Tinted	 Barcelona
 2-2 Piece Arched Stockton	 Glue Chip	 Wrought Iron
 3 Piece Arched Stockton	 Oscure	 Outside Lock
 4 Piece Arched Stockton	 LaSalle	
 Madison	 Newport	<p>Wind can be unpredictable and destructive. This is why the C.H.I. Windbreaker Series was designed, tested, and built to the most rugged specifications. Wind chamber tested to ensure wind-load resistance, this extra-sturdy series provides enhanced defense against the elements.</p>
 2-2 Piece Arched Madison	 Hampton	
 3 Piece Arched Madison	 Florence	
 4 Piece Arched Madison		

WHITE

ALMOND

SANDSTONE

DARK OAK

LIGHT OAK

MAHOGANY

CEDAR

accents

COLOR SELECTIONS⁵

APPEARANCE PACKAGE[®] - Ask your door professional for more information.

All hardware (excluding torsion shafts, drums, springs and cables), track and struts are powder coated white. White 10 ball nylon rollers included.

VISIT YOUR DOOR PROFESSIONAL AT:

C.H.I. Overhead Doors are manufactured in Arthur, Illinois, USA.

FOOTNOTES

1. R-value testing is in accordance with ASTM C518 standards.
2. Extra heavy paint system consists of .25 mil. primer with rust inhibitor and a .75 mil. coating of baked-on polyester paint.
3. Appearance Packages are standard white, custom colors are available at an extra charge.
4. All designer lights are either transparent or semi-transparent. For all available window options, please see our Glass Option Brochure, or visit your C.H.I. Overhead Doors Distributor.
5. Two-tone color variation exists with Accents wood tone. For all color selections contact your local C.H.I. distributor for exact color samples.
6. Barcelona hardware options include handles or pull-rings and hinges or corner brackets. Pull-rings and corner brackets are an additional charge.
7. Chlorofluorocarbon (CFC) free.



DOOR CONSTRUCTION



This model utilizes a 1-13/18" CFC⁷ free polystyrene insulation glued on both sides between 27-ga. exterior and 27-ga. interior skins. The front and back skins are locked together in a tongue and groove design for years of worry free protection.

5283/5983.....R-value¹ - 9.65

All information presented is based on the specifications and features available at the time of printing and is subject to change without notice.